



For U.S. registered gliders

ASK 21

**Flight Manual
Instruction for
Continued Airworthiness
Repair Manual**

I. GENERAL

I.1 LOG OF REVISION

Revisions No.	Pages affected	Description	LBA approval, signature	Date
01	13 dated: Feb. 16, 1984	Modification of the Flight Manual, TN-No. 13	Feb. 23, 1984 signed by Mr. Frieß	Feb. 16, 1984
02	2, 14, 15, 42, 43 dated: Dec. 20, 1983	Automatic elevator Connection, TN-No. 11	March 9, 1984 signed by Mr. Frieß	Dec. 20, 1983
03	2 and 13 dated: June 4, 1984	Amendment to the Flight Manual, TN-No. 13 a	June 6, 1984 signed by Mr. Frieß	June 4, 1984
04	2 and 21 dated: May 16, 1984	Amendment to the Manuals in English language, TN-No. 14	May 28, 1984 signed by Mr. Frieß	May 16, 1984
05	2, 25, 26, 28a, 27 dated: May 25, 1984	New canopy locking system, TN-No. 15	June 8, 1984 signed by Mr. Frieß	May 25, 1984
06	2, 3, 4, 30, 31, 42, 42a, 43 dated: Oct. 16, 1987	Change / supplement to the Flight Manual, TN-No. 20	Nov. 3, 1987 signed by Mr. Frieß	Oct. 16, 1987
07	Annex	New variant of tow release, TN-No. 21	March 1, 1990 signed by Mr. Schmaljohann	17.08.90
08	2, 42a, 43a, 43b	Amendment to the Flight Manual, TN-No. 22	Dec. 4, 1990 signed by Mr. Skov	14.12.90
09	2, 22, 24, 33, 34	Revision of the Flight Manual, TN-No. 23	Jan. 29, 1991 signed by Mr. Kopp	15.04.91
10	Annex	AD 93-001/2/3, L'Hotellier instructions for the maintenance, Rev. E 03/94	09.04.98 by LBA	27.04.98

I.2 PAGES INCLUDED

Cover page		16	March 9, 1983
1	March 9, 1983	37	March 9, 1983
2	Jan. 91	38	March 9, 1983
3	Oct. 16, 1987	39	March 9, 1983
4	Oct. 16, 1987	40	March 9, 1983
5	March 9, 1983	41	March 9, 1983
6	March 9, 1983	42	Oct. 16, 1987
7	March 9, 1983	42a	26.11.90
8	March 9, 1983	43a	26.11.90
9	March 9, 1983	43b	26.11.90
10	March 9, 1983	44	March 9, 1983
11	March 9, 1983	45	March 9, 1983
12	March 9, 1983	46	March 9, 1983
13	June 4, 1984	47	March 9, 1983
14	Dec. 20, 1983	48	March 9, 1983
15	Dec. 20, 1983	49	March 9, 1983
16	March 9, 1983	50	March 9, 1983
17	March 9, 1983	51	March 9, 1983
18	March 9, 1983	52	March 9, 1983
19	March 9, 1983	53	March 9, 1983
20	March 9, 1983	54	March 9, 1983
21	May 16, 1984	55	March 9, 1983
22	Jan. 91		
23	March 9, 1983		
24	Jan. 91		
25	May 25, 1984		
26	May 25, 1984		
26a	May 25, 1984		
27	May 25, 1984		
28	March 9, 1983		
29	March 9, 1983		
30	Oct. 16, 1987		
31	Oct. 16, 1987		
32	March 9, 1983		
33	Jan. 91		
34	Jan. 91		
35	March 9, 1983		

I.3. CONTENTS

- I. General
- I.1 Log of revisions
- I.2 Pages included
- I.3 Contents
- I.4 3-Side-View
- I.5 Description

(Beginning of JAR22-required and LBA-approved part.)

- II. Operating limitations
 - II.1 Airworthiness category
 - II.2 Permitted operations
 - II.3 Minimum equipment
 - II.4 Airspeed limitations & load factor limits
 - II.5 Crew
 - II.6 Weights
 - II.7 In flight C.G. range
 - II.8 Weight and balance information
 - II.9 General survey drawing 1 : 50
 - II.10 Placards and instruments color codes
 - II.11 Description of symbolic placards
- III. Emergency procedures
 - III.1 Recovery from spin
 - III.2 Canopy jettisoning & emergency bailout
 - III.3 Flights through precipitation
 - III.4 Wing drooping
 - III.5 Ground looping
- IV. Normal operating procedures
 - IV.1 Cockpit layout and controls
 - IV.2 Daily inspections
 - IV.3 Checks prior to take off
 - IV.4 Take off
 - IV.5 Free flight
 - IV.6 Low speed flight and wing drooping
 - IV.7 High speed flight
 - IV.8 Approach and landing
 - IV.9 Aerobatics

- V. Rigging and de-rigging
- V.1 Rigging
- V.2 De-rigging
- V.3 Parking
- V.4 Road transport
- V.5 Preventive maintenance

- VI. Center of gravity
- VI.1 Weighing procedure for empty weight C.G.
- VI.2 Empty weight C.G. range
- VI.3 Weighing record
- VI.4 Calculation of the in flight C.G.

Appendix

Flight polar

Lubrication Scheme

Rigging data (for adjustment of control surfaces, etc.)

I.4 THREE-SIDE-VIEW

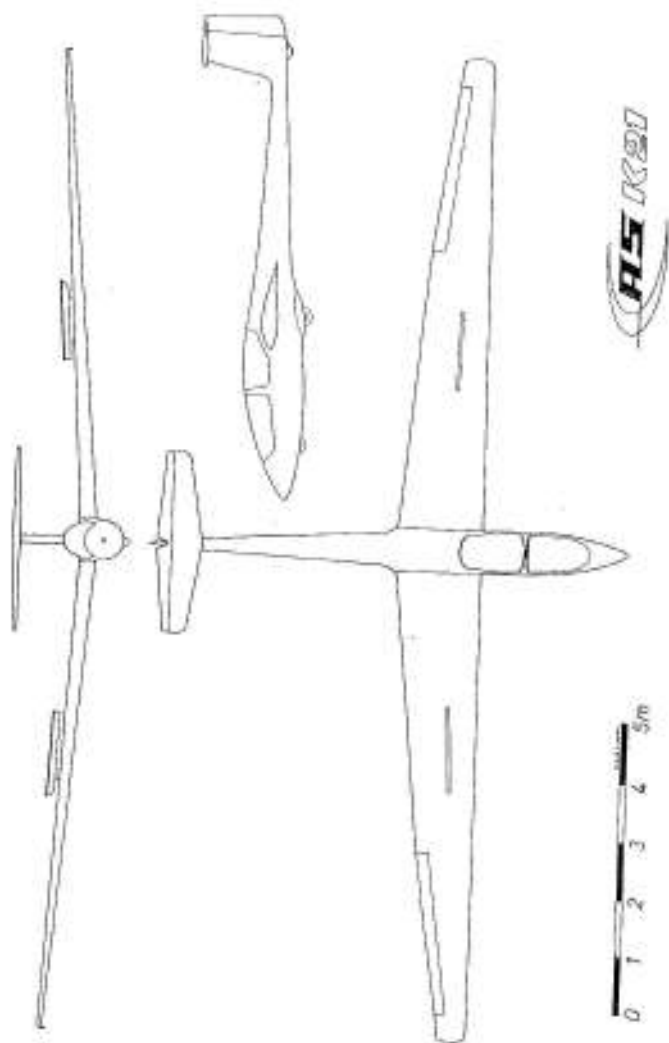

March 9, 1983

I.5 DESCRIPTION

The ASK 21 is designed to meet the needs of modern gliding training. It has an all fiberglass sandwich structure.

Midwing with T-tail, tandem seat arrangement, airbrakes on upper wing only.

The glider is stressed for aerobatics (inverted flight included).

Technical Data

Span	17,00 m	=	55,74 ft
Length	8,35 m	=	27,4 ft
Height	1,53 m	=	5,02 ft
Aspect ratio	16,1		
Wing area	17,95 m ²	=	192,96 sqft
Max. all up weight	600 daN	=	1320 lbs
Max. wing loading	33,4 daN/m ²	=	6,84 lbs/sqft

Airfoil: Wortmann FX 302 196 (inner wing)
 Wortmann FX 60 -126 (wing tip)

Winch Tow: Weak Link 1000 daN

Aero Tow : Weak Link 600 daN

II. OPERATING LIMITATIONS

II.1 AIRWORTHINESS CATEGORY

A (Aerobatics) according to LPSM.
Certification basis: Airworthiness Requirements for Sailplanes and Powered Sailplanes dated 1.11.1975.

II.2 PERMITTED OPERATIONS

The glider is certified for VFR flights during daytime (VFR day).

The approved operation class is indicated by a data placard on the instrument panel. Depending on the respective equipment the glider may be licensed for traffic for the following categories:

1. Airworthiness Category U (Utility), according to VFR with equipment as under II.3 a)
2. Airworthiness Category A (aerobatics), with equipment as under II.3 a) and II.3 b) for the following aerobatics :

Loop, Stall Turn, Split 'S',
Immelmann, Slow Roll, Inverted
Flights, Spin, Steep Climbing
Turn, Lazy Eight, Chandelle.

II.3 MINIMUM EQUIPMENT

- a) 2 airspeed indicators;
2 altimeters;
2 four-point safety harnesses;
2 seat cushions, at least 10 cm thick when loaded,
or parachutes (automatic or manual);
Weight & balance data placard for both seats;
Data plate;
Flight Manual.

- b) Additional equipment for aerobatics
Bottom straps for safety harnesses in both seats;
1 G-meter for front seat;
Foot loops on rudder pedals;
Parachute (automatic or manual).

II.4 AIRSPEED LIMITATIONS AND LOAD FACTOR LIMITS

Max. permissible speed (calm air):

$$V_{NE} = 151,2 \text{ kts} = 174,00 \text{ mph} = 280 \text{ km/h}$$

Max. permissible speed (rough air):

$$V_B = 108,0 \text{ kts} = 124,3 \text{ mph} = 200 \text{ km/h}$$

Max. maneuvering speed:

$$V_M = 97,2 \text{ kts} = 112,0 \text{ mph} = 180 \text{ km/h}$$

Max. speed with airbrakes extended:

$$V_{LE} = 151,2 \text{ kts} = 174,00 \text{ mph} = 280 \text{ km/h}$$

Stall speed with airbrakes extended:

$$V_{S1} = 37,0 \text{ kts} = 42,3 \text{ mph} = 68 \text{ km/h}$$

Stall speed with airbrakes retracted:

$$V_{S0} = 35,0 \text{ kts} = 40,4 \text{ mph} = 65 \text{ km/h}$$

The following safe load factors must not be exceeded (airbrakes retracted, symmetrical maneuvers):

$$\text{At max. maneuvering speed } V_M \quad n = \begin{matrix} +6,5 \\ -4,0 \end{matrix}$$

$$\text{At max. permissible speed } V_{NE} \quad n = \begin{matrix} +5,3 \\ -3,0 \end{matrix}$$

Rough air is defined as turbulence that can be expected in wave rotors, thunderstorms, whirlwinds, and when crossing mountain ridges.

Maneuvering speed is the highest speed at which full deflections of the control surfaces are still permitted.

With max. permissible speed V_{NE} only 1/3 of the possible deflections are permitted.

True airspeed (TAS) is, however, relevant for safety against flutter. Therefore, one must take into account that with increasing altitude the true airspeed is higher than the reading of the airspeed indicator because of the decreasing air density.

$$V_{NE} = 151 \text{ kts} \quad n = \begin{matrix} +5,3 \\ -3,0 \end{matrix}$$

V_{NE} at various altitudes

Altitude ft	V_{NE}	
	knots	mph
5000	151	174
10000	144	165
15000	132	152
20000	121	139

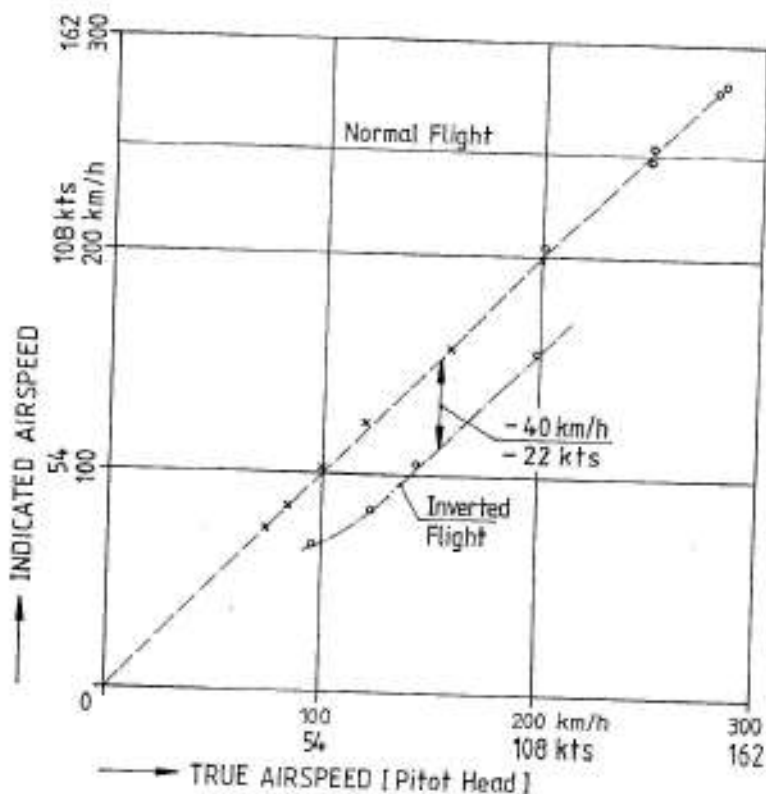

POSITION ERROR

With normal flights the position error of the airspeed indicator is negligible within the whole range up to 280 km/h (151 kts).

With inverted flights the airspeed indicator reads too low, i.e. up to -40 km/h (22 kts).

By attaching an extension tube this error may be eliminated. (see also pages 27/28).

The extension tube must project at least 70 mm (2,75 in) past the fuselage nose.

Airspeed indicator markings (IAS)

Red line (max. permissible airspeed):

151,2 kts = 174,0 mph = 280 km/h

Yellow arc (caution range):

97,2 - 151 kts = 112 - 174 mph = 180 - 280 km/h

Green arc (normal range):

43,0 - 97 kts = 50 - 112 mph = 80 - 180 km/h

Yellow triangle (approach speed):

49,0 kts = 56,0 mph = 90 km/h

II.5 CREW : 2 persons

Minimum crew : 1 person (min.weight 70 daN = 154 lbs)

Caution: Solo flights may only be conducted from
the front seat !

II.6 WEIGHTS

Empty weight approx. 792 lbs = 360 daN

Max. all up weight 1320 lbs = 600 daN

Max. weight of non lift
producing members 902 lbs = 410 daN.

II.7 IN FLIGHT CENTER OF GRAVITY RANGE

The approved in flight C.G. range is from 9,21 (234 mm) = 18,46 inches (469 mm) behind the datum line; equivalent to 20 % - 41,1 % of the MAC = 44,13 inches (1121 mm). With a 0,31 inches (8 mm) behind leading edge center part of the wing.

II.8 WEIGHT & BALANCE INFORMATION

Max. payload front seat (pilot incl. parachute):
242 lbs = 110 daN.

Min. payload front seat (pilot incl. parachute):
154 lbs = 70 daN.

Caution: Short weight in the front seat must be compensated by ballast (installation of lead discs in the nose; 1 lead disc = 2,76 lbs pilot weight).

Number of lead discs	Min. payload front seat	
	daN @ kg	lbs
0	70,0	154,32
1	68,75	151,57
2	67,5	148,81
3	66,25	146,06
4	65,0	143,30
5	63,75	140,54
6	62,5	137,79
7	61,25	135,03
8	60,0	132,28
9	58,75	129,52
10	57,5	126,77
11	56,25	124,01
12	55,0	121,25

Max. payload rear seat (pilot incl. parachute) :
242 lbs = 110 daN.

1 kg = 2,2046223 lbs

Setting of placards

II. 9

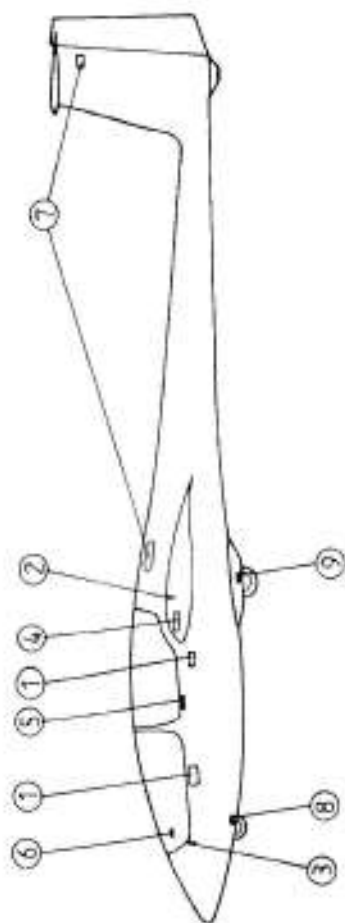

Setting of placards [Only with tail wheel]

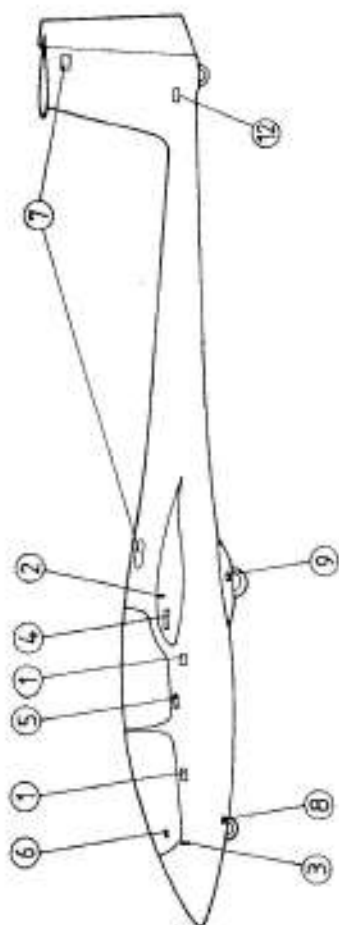

Segelflugzeugbau A. Schleicher Poppenhausen	
Model	Serial no.
DATA PLACARD	
Approved for:	
Max. speed for calm air	280 km/h
Max. speed for rough air	200 km/h
Max. maneuvering speed	V_W 180 km/h
Max. aero tow speed	V_F 180 km/h
Max. winch launch speed	V_W 150 km/h
WEIGHT AND BALANCE	
Min. payload front seat	kg
Max. payload front seat	kg
Max. payload rear seat	kg
Baggage in wingroots	max. 2 x 10 kg
Max. permissible all-up weight	kg

①
2 off

④
Loading of baggage compartment: max. 10 kg
2 off

- ⑥
1 off
- Pre Take Off Check:**
1. Controls easy to operate?
 2. Airbrakes locked?
 3. Trim in the center position?
 4. Parachute and safety harness fastened?
 5. Altimeter adjusted to field height or to zero?
 6. Radio "ON" and adjusted to proper frequency?
 7. Both canopies locked?

- ⑤
1 off
Rear
- Attention! Emergency bailout!**
- Pull back both canopy side-latches and push canopy upwards.
 - Undo safety harness.
 - Get up and bail out.
 - With manual chute seize release grip and pull out entirely after 1-3 sec.

②



A. Schleicher
5418 Pappenhausen

Model: ASK 21
Serial no: 21 XXX
Registration letters :
Made in West Germany

③
1 off

Aerobatics prohibited!
Equipment as under airworthiness category "U" (Utility)

For equipment without g-meter and bottom strap.

③
1 off

Aerobatics as per Flight Manual
Equipment as under airworthiness category "A" (Acrobatic)

For equipment with g-meter and bottom strap.

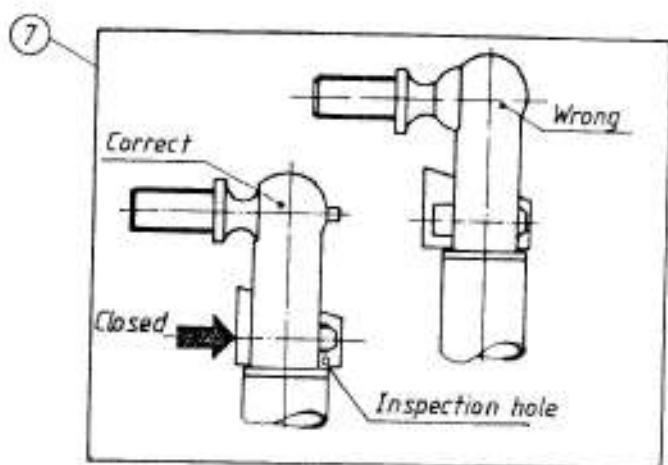

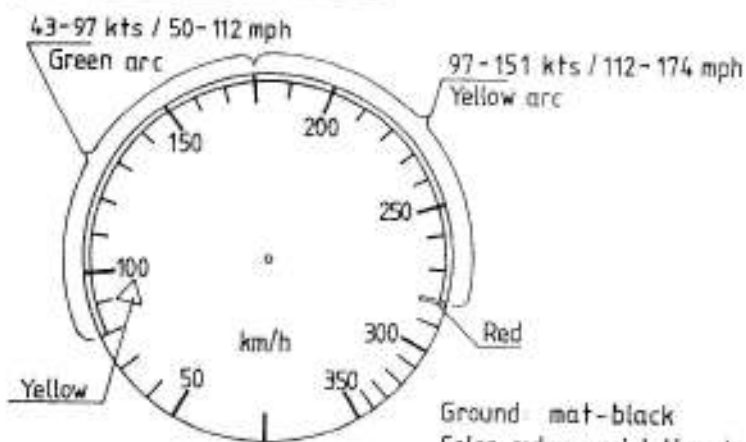
Airspeed indicator color codes

Ground mat-black
Color codes and letter in
luminous paint.

G-meter color codes

a) Positive range

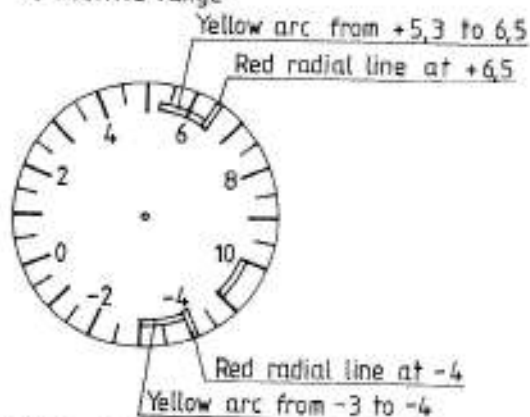

b) Negative range

II.11 DESCRIPTION OF SYMBOLIC PLACARDS

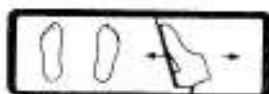

Rudder pedals adjustment: grey knob on RH side of the console.

To adjust pedals backwards:

Take your feet off the pedals and pull pedals backwards; then let go the grey knob and load the pedals in order to lock them.

To adjust pedals forwards:

Pull grey knob and push pedals forwards with your heels; then let go the grey knob and load the pedals in order to lock them.



Airbrakes: blue lever in the LH arm rest; pull to extend airbrakes.



Trim: noseheavy.



Trim: tailheavy.



Tow release: yellow knob LH below canopy frame.



To open canopy: pull back the white levers LH and RH on the canopy frame.





Canopy emergency jettisoning:
push to the left the red flat
knob above the instrument panel.



Ventilation

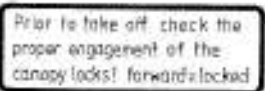

This placard must be fitted in
the front and rear cockpit in
full view of the pilot.

III. EMERGENCY PROCEDURES

III.1 RECOVERY FROM SPIN

According to the standard procedure spinning is terminated as follows:

- a) Apply opposite rudder (i.e. apply rudder against the direction of rotation of the spin).
- b) Short pause (hold control inputs for about 1/2 spin turn).

Warning: Disregarding the pause will result in slower recovery!

- c) Ease the control column forward (i.e. give in to the pressure of the stick) until the rotation ceases and sound airflow is established again.

Warning: Full forward stick may retard or even prevent the recovery!

- d) Centralise rudder and allow glider to dive out.

The altitude loss from the beginning of the recovery until the normal flight attitude is regained is about 80 meter (260 feet).

Note: During spins the ASK 21 oscillates in pitch. From a steep nose down spin recovery according to the standard procedure is up to 1 turn, from a flat spin less than 1 turn.

III.2 CANOPY JETTISONING AND EMERGENCY BAIL OUT

Front canopy:

- a) Move lever with the red knob above the instrument panel to the left and push canopy upwards.
- b) Open safety harness.
- c) Get up and bail out.
- d) With manual chute seize release grip and pull out entirely after 1 to 3 seconds.

Rear canopy

- a) Pull back both canopy side locks and push canopy upwards.
- b) Open safety harness.
- c) Get up and bail out.
- d) With manual chute seize release grip and pull out entirely after 1-3 seconds.

If circumstances allow, the front pilot should allow the rear pilot to bail out first.

III.3 FLIGHTS THROUGH PRECIPITATION

With wet or slightly iced wings or with insect accumulation there will be no deterioration in flight characteristics.

However, one has to reckon with a rather considerable deterioration in flight performance. This must be taken into account especially on landing final approach.

Add a safety margin of 5 knots = 10 km/h for approach speed !

III.4 WING DROPPING

The glider stalls extremely benign. Nevertheless one always has to face the possibility of wing dropping because of turbulence. In that case push stick forward immediately and apply opposite rudder against a noticeable turn at the same time to regain a normal flight attitude. If the rudder deflection against the turn is forgotten, a spin may occur even if the stick pressure is released.

III.5 GROUND LOOPING

For normal conditions, smooth runway, short grass, one may take off with the wing on the ground without having to fear a change in the direction.

High grass and rough ground, however, may cause ground looping. In that case release the tow rope immediately.

IV. NORMAL OPERATING PROCEDURES

IV.1. COCKPIT LAYOUT AND CONTROLS

Front seat:

- No.1: Stick.
- No.2: Trim; flat lever with green knob LH of stick.
- No.3: Rudder pedal adjustment; grey knob at the console.
- No.4: Airbrakes with wheelbrake; blue lever in the left arm rest.
- No.5: Release cable; yellow knob on left cockpit wall below the canopy frame.
- No.6: Canopy emergency jettisoning; horizontal lever with red flat grip above the instrument panel cover; to the left = OPEN.
- No.7: Front canopy locking;
White swivel levers on left and right canopy frame.
To open canopy: pull back both levers.
To lock canopy: push both levers forwards, parallel to the canopy frame.
- No.8: Ventilation nozzle; on right cockpit wall below the canopy frame; revolving and lockable.
- No.9: Back rest; the back rest is adjustable by tilting it from the bottom upwards and forwards (see sketch); in normal flight attitudes the back rest cannot shift by itself.
Very tall pilots may fly without the back rest.
- No.10: Trim indicator; in the right arm rest behind the ventilation nozzle.

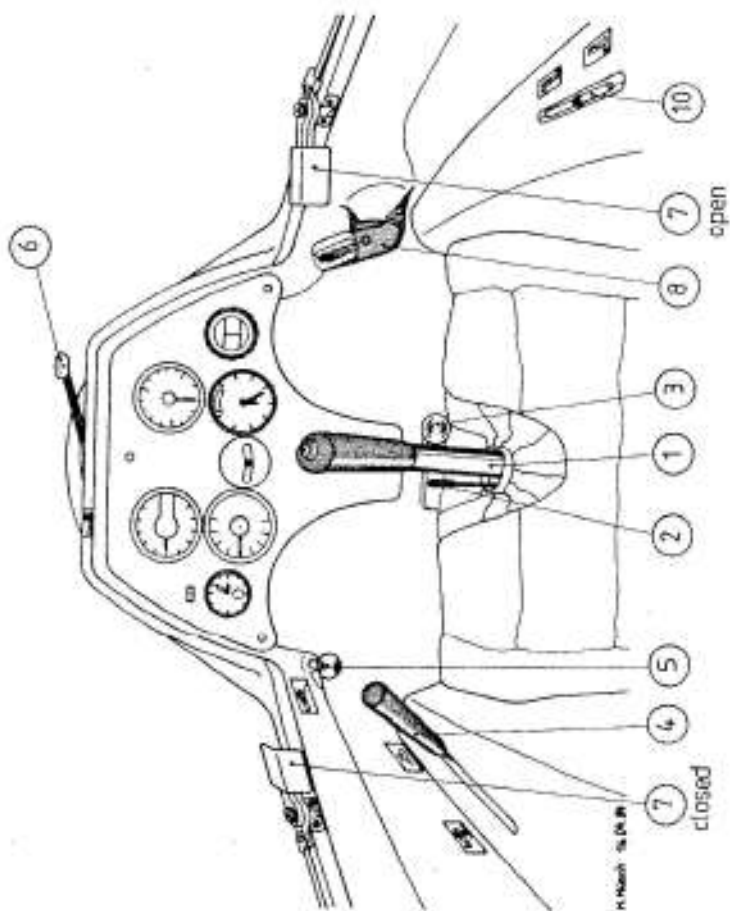
Front seat

Rear seat:

- No.1: Stick.
- No.2: Trim; flat lever with green knob LH of stick.
- No.3: Rudder pedal adjustment with circular grip in front of stick.
- No.4: Airbrakes with wheelbrake; blue lever in the left arm rest.
- No.5: Release cable; yellow knob on left cockpit wall below the canopy frame.
- No.6: Rear canopy locking = Canopy emergency jettisoning; red swivel levers on left and right canopy frame.
To open canopy: pull back both levers.
To lock canopy: push both levers forwards, parallel to the canopy frame.
- No.7: Ventilation nozzle; on right cockpit wall below the canopy frame; revolving and lockable.
- No.8: Back rest; the back rest is adjustable by tilting it from the bottom upwards and forwards (see sketch); in normal flight attitudes the back rest cannot shift by itself.
Very tall pilots may fly without the back rest.
- No.9: Trim indicator; in the right arm rest behind the ventilation nozzle.

BACK REST ADJUSTMENT

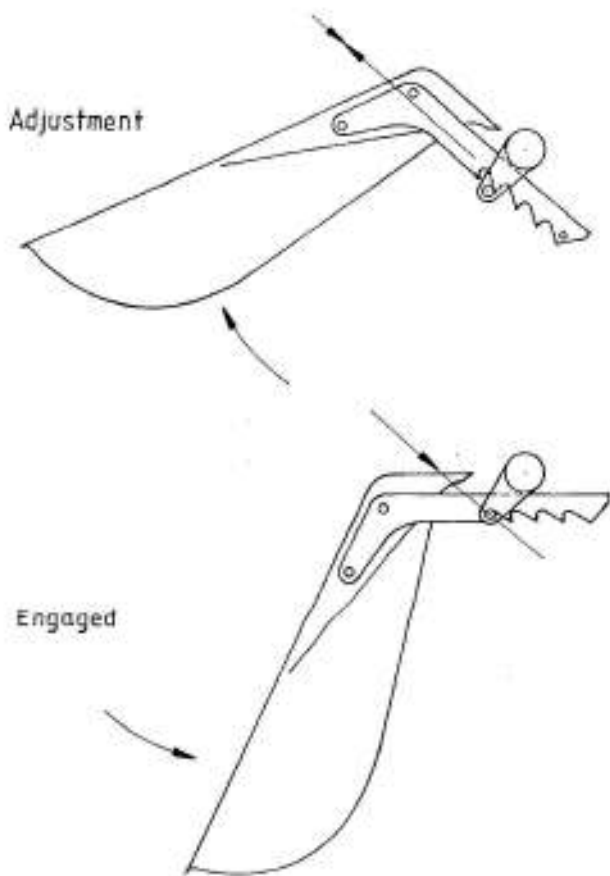

DAILY CHECKS [see page 30 FM]

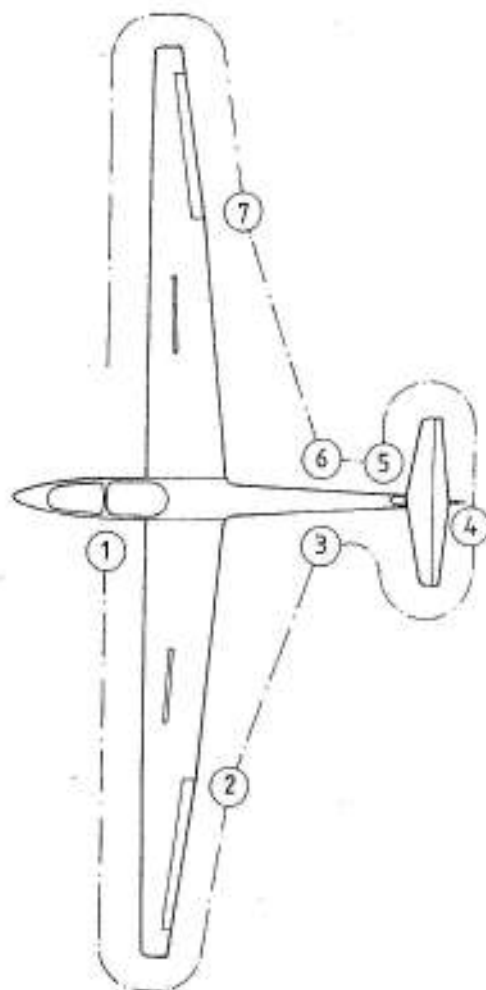

IV.2 DAILY INSPECTIONS

Prior to flight operations the following checks must be accomplished:

- 1.a. Open canopy! Check that the main pins are properly secured.
 - b. Check the proper connection of the ailerons and airbrakes through the access hole on the left side above the wing. Are the quick-release connectors secured with spring clips?
 - c. Check for foreign bodies!
 - d. Check the control circuits force and that all controls are free-moving. Apply full deflections and load the control circuits with fixed controls and airbrakes. Check the plastic tubes inside the S-shaped rudder pedal tubes for proper and tight fit.
 - e. Check tire pressure:
 - Nose wheel 2,0 bar (29 psi)
 - Main wheel 2,7 bar (39 psi)
 - Tail wheel (if installed) 2,3 bar (33,6 psi).
 - f. The condition and function of the tow release mechanism is to be checked. Actuate the tow release: does it snap back freely? Engage and disengage the ring pair. Check the automatic release of the C.G. towing hook with the ring pair which must release automatically backwards.
 - g. Check the wheel brakes. Pull the airbrake lever: at the end of its travel an elastic resistance must be felt.
- 2.a. Check upper and lower wing surface for damages!
 - b. Aileron: its condition, free-movingsness and play is to be checked! Check also the pushrod connection.
 - c. Airbrake: its condition, fit and locking is to be checked.
3. Check the fuselage for damages, in particular also the bottom side.
 4. Check that the tailplane is properly assembled and secured. Check also the pushrod connection! Secured with spring clips?



IV.4 TAKE OFF

Winch tow

Trim neutral.

Max. tow speed: 81 kts = 93 mph = 150 km/h.

The glider features a tow release for winch tow in front of the main wheel.

The most favorable tow speed is 50-60 kts = 56-68 mph = 90-110 km/h.

There is little pitch up tendency during initial tow. In the upper third of the tow additional altitude may be gained by slight back pressure.

Tow release: pull the release knob several times to the stop.

Aero tow

Aero tows only at the nose release in front of the nose wheel. Recommended tow rope length: 100-200 ft.

Trim neutral.

Max. tow speed: 97 kts = 112 mph = 180 km/h.

The most favorable tow speed during climb is 50-75 kts = 56-87 mph = 90-140 km/h.

Take off may be done with the wingtip on the ground. Getting the wings level is no problem. However, the pilot is advised to be careful with high grass and very rough ground.

Lift off takes place at about 40 kts = 47 mph = 75 km/h.

IV.5 FREE FLIGHT

The glider may be flown up to $V_{WE} = 151 \text{ kts} = 174 \text{ mph} = 280 \text{ km/h}$.
 Up to manoeuvring speed of $97 \text{ kts} = 112 \text{ mph} = 180 \text{ km/h}$ full control deflections can be applied. At higher speeds the controls must be applied more carefully.
 At V_{WE} only 1/3 of the max. possible deflections must be applied.

IV.6 LOW SPEED FLIGHT, WING DROPPING AND SPINS

With the stick back a distinct tail buffet is felt.

The glider is very benign in low speed flight. By use of normal aileron deflections the wings may be kept level down to minimum speed even with aft C.G. positions.

With normal rudder deflections no wing dropping is found. Yaw angles of up to 5° have no significant influence on the wing dropping attitude.

Also rapid pulling up into 30° pitch does not cause wing dropping, but only a gentle nose drop. The same applies for stalling out of a 45° turn.

But one has to point out that even the most benign glider needs speed in order to be controllable.

In turbulence this is especially important when also a wing dropping may occur.

Spin development from wing dropping strongly depends on the C.G. position and also to some extent from the pilot reaction.

For C.G. positions forward of 315 mm aft of datum the ASK 21 does not spin at all. This configuration applies to 2 heavy pilots.

For C.G. positions from 320 mm through 385 mm aft of datum more incipient spin turns are possible followed by self recovery after 4 1/2 turns at most. Such C.G. positions are possible in dual flight with a lightweight pilot in the front seat.

For C.G. positions aft of 400 mm behind datum controllable sustained spins are possible. Such a C.G. position is usually only possible with one lightweight pilot in the front seat.

Note: During spins the ASK 21 oscillates in pitch. From a steep nose down spin recovery according to the standard procedure is up to 1 turn, from a flat spin less than 1 turn.

The speed at which the stall takes place depends on the payload. The following standard values are applicable:

Single: All up weight 1034 lbs = 470 daN,
 without airbrakes 65 km/h (35 kts) IAS
 with airbrakes 68 km/h (37 kts) IAS.

Dual: All up weight 1320 lbs = 600 daN,
 without airbrakes 74 km/h (40 kts) IAS
 with airbrakes 77 km/h (42 kts) IAS.

IV.7 HIGH SPEED FLIGHT

The glider shows no flutter tendency within the permissible speed range.

With airbrakes extended in a 45° dive the speed remains below V_{NE} = 151 kts = 174 mph = 280 km/h; it goes up to 125 kts = 144 mph = 232 km/h at an all up weight of 1230 lbs = 600 daN.

IV.8 APPROACH AND LANDING

The most favorable approach speed is 49 kts = 56 mph = 90 km/h. With turbulence it may be advisable to increase slightly the approach speed.

Even steep approaches may be slowed down efficiently with the airbrakes at the beginning of the landing final approach.

Note: The airbrakes increase the stalling speed by about 1,6 kts = 3 km/h.

Sideslipping is also suitable as an approach control. With full rudder during the sideslipping the rudder pressure decreases to zero; the rudder must be pushed back.

During sideslipping the airspeed indication goes to zero reading.

Rev. no. / Date Sig.
 TN20 Jan. 91 Waibel

Author Date
 Kaiser Mar. 9, 1983

Page no.
 LBA- 34
 APP.

IV.9 AEROBATICS

Warning : Even a glider which is approved for full aerobatics does not have infinite strength capacities. Most hazardous are aerobatics which get out of control or are badly executed, as they result in high loads.

Therefore, it is urgently recommended to have oneself guided by an experienced flight instructor. The ASK 21 being an approved two-seater for full aerobatics offers this possibility.

Such guidance is even prescribed according to § 69 (4) of the German LuftPersPO (Aviation Personnel Test Regulations) dated January 9, 1976. Following § 96 (3) of the said LuftPersPO an adequate experience is required from flight instructors.

Note : the normal airspeed indicator system shows a large pressure error in inverted flight during which the airspeed indicator reads 40 km/h = 22 kts too low. When extending the pitot head by attaching a brass tube - 12 Ø x 1; 5,5 in = 140 mm in length - this error disappears. The tube must project in the front at least 2,75 in = 70 mm. For normal flights this is not necessary. In order to avoid damage when parking the glider in the hangar, this tube should not be left on any longer than necessary.

Permissible indicated speeds

Inverted flight without pitot head extension:

V_{NE} : Single 35-130 kts = 65-240 km/h.

Dual 38-130 kts = 70-240 km/h.

Indicated maneuvering speed 75 kts = 140 km/h

Indicated max. speed 130 kts = 240 km/h.

Inverted flight with pitot head extension:

Indicated maneuvering speed 97 kts = 180 km/h

Indicated max. speed 151 kts = 280 km/h

Indicated stall speed 47 kts = 87 km/h

with two occupants

ATTENTION : never release stick and rudder pedals when flying aerobatics.

With aerobatics instruction a reliable agreement must be made between instructor and student flyer with regard to the communication system for the mutual taking over of the controls.

Airbrakes must be extended as soon as the pilot loses the control of the glider or as the speed increases unvoluntarily too fast.

Exception: "Tail sliding" !!!

The trim remains in the center position for aerobatic maneuvers. Don't ever change the trim when flying aerobatics !!

PROHIBITED AEROBATICS

All abrupt aerobatic maneuvers

Loop forward

Tail sliding.

Extension tube for total pressure head with inverted flights

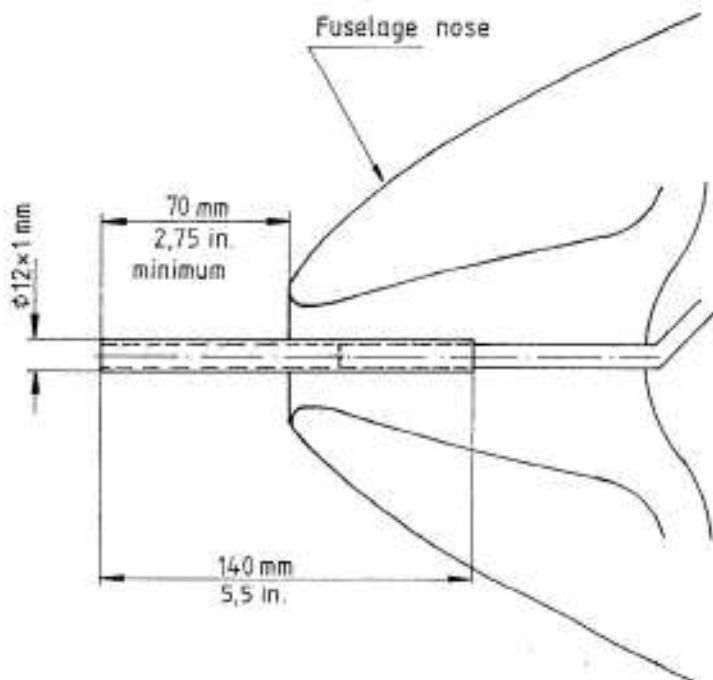

Brass tube 5,5 in = 140 mm in length (12 \emptyset x 1).
One may also use a suitable plastic tube provided that it is sufficiently stiff and straight.

	<u>Indicated entrance speed</u>	<u>Max. acceleration</u>
Loop upward	Single: 84 kts = 155 km/h	2-3 g
	Dual: 92 kts = 170 km/h	
Stall Turn	Single: 89 kts = 165 km/h	3 g
	Dual: 97 kts = 180 km/h	
Split 's'	Single: 92 kts = 170 km/h	2-3 g
	Dual: 97 kts = 180 km/h	
Immelmans	Single: 89 kts = 165 km/h	2,5-3,5 g
	Dual: 97 kts = 180 km/h	
Slow Roll	Single: 81 kts = 150 km/h	
	Dual: 89 kts = 165 km/h	
Steep Climbing Turns & Lazy Eight	Single: 76 kts = 140 km/h	
	Dual: 81 kts = 150 km/h	
Chandelle	Single: 96 kts = 160 km/h	
	Dual: 98 kts = 175 km/h	



L O O P

Entrance speed:

Single 84 kts = 155 km/h

Dual 92 kts = 170 km/h

Max. g = 2-3.



S T A L L T U R N

Entrance speed:

Single 89 kts = 165 km/h

Dual 97 kts = 180 km/h

Max. g = 3.



S P L I T 'S'

Full up at least 30°!

Altitude loss approx. 328 ft = 100 m.

Entrance speed:

Single 92 kts = 170 km/h

Dual 97 kts = 180 km/h

Max. g = 2-3.



I M M E L M A N N

Entrance speed:

Single 89 kts = 165 km/h

Dual 97 kts = 180 km/h

Max. g = 2,5-3,5.



S L O W R O L L

Entrance speed:

Single 81 kts = 150 km/h

Dual 89 kts = 165 km/h.



I N V E R T E D F L I G H T

Note: with the inverted flight the fuselage nose will be unexpectedly high above the horizon.



S P I N



L A Z Y E I G H T

Entrance speed:

Single 76 kts = 140 km/h

Dual 81 kts = 150 km/h.

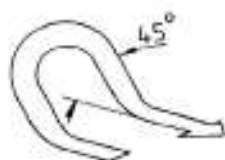

S T E E P C L I M B I N G
T U R N

Entrance speed:

Single 76 kts = 140 km/h

Dual 81 kts = 150 km/h.



C H A N D E L L E

Entrance speed:

Single 86 kts = 160 km/h

Dual 95 kts = 175 km/h.

V. RIGGING AND DE-RIGGING

V.1 RIGGING

Rigging the ASK 21 can be carried out by four persons without mechanical assistance, and by three persons with the use of a fuselage stand or a wing support.

Prior to rigging, clean and grease all pins, belts, bushings and control system connections.

1. Set up the fuselage and hold it horizontal.
2. Plug the spar fork of the left wing into the fuselage and - if available - place a wing support under the wing end.
3. Offer up the right wing and align the main pin fittings.
4. Press in the main pins and secure. Never insert the rear wing attachment pins prior to the main pins !
5. Press in the rear wing attachment pins; unscrew the T-tool and check whether the safety lock is engaged.
6. Connect and lock the aileron control linkages in the fuselage behind the spar tunnel. You must be able to touch the ball pivot by feeling through the slot in the socket. Also check the proper engagement of the safety lock by pushing it on to close ! Secure them with spring clips!
7. Connect and lock the airbrake control linkages in the fuselage behind the spar tunnel. Secure them with spring clips!

8. The tailplane is fitted onto the fin from the front. (see Fig. V.2-1 and V.2-2).
Now the Allan bolt at the leading edge is screwed in; this should be screwed in tightly until the spring-loaded safety pin snaps out over the screw head as far as the socket.
9. Connect the elevator and safety with a spring clip !

Note, if your glider uses an automatic elevator connection: after cleaning and lightly greasing the plug-in elevator connections, the tailplane is fitted onto the fin from the front; both elevator panels must be fitted into their connectors simultaneously. Then the tailplane is pushed back until the Allan bolt at the leading edge can be screwed in; this should be screwed in tightly until the spring-loaded safety pin snaps out over the screw head as far as the socket.

10. Carry out a pre-flight check referring to the Check List (see Section VII, p.43, of the Instructions For Continued Airworthiness !
11. The control circuits must be subjected to an operational test.
12. Check condition and function of the wheel brake; check the tire pressure.
See also Section IV.2 DAILY INSPECTIONS in this Manual.

V.2 DE-RIGGING

De-rigging is carried out in the reverse sequence to that of rigging. It must be taken care that the rear wing attachment pins have to be removed prior to the main pins.

WARNING: For derigging the horizontal tail from the fin it has to be regarded that only the method according to Fig. V.2-2 is used.

Fig. V.2-1

WRONG: Twist movement

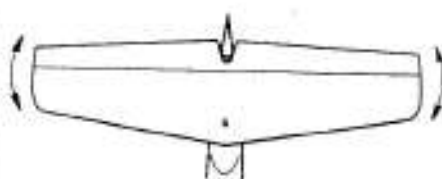

Fig. V.2-2

RIGHT: Pitch movement



V.3 PARKING

When parking the glider, the canopies have to be closed !

When an ASK 21 is parked on an airfield in the sunshine (this must also be observed during the waiting time until take-off when the pilots are already on board) the canopies must not be left open for some time.

Depending on the position of the sun and the intensity of the radiation, the burning-glass effect of the canopies can cause a slow fire in the area of the instrument panel or the headrest respectively.

Therefore, if you have to store the glider outside, it is absolutely necessary always to close the canopies and to cover them with a white cloth.

V.4 ROAD TRANSPORT

The design of a glider trailer is another subject and cannot be discussed in all details here. Of course, a closed trailer is preferable. But also an open trailer may serve the purpose, the latter is generally simpler and lighter. It is important that all components are well fixed and have a large support surface.

A structural components survey drawing which can be used for the building of a trailer, can be obtained from ALEXANDER SCHLEICHER.

WARNING: In no case must the elevator actuator fitting be loaded. This fitting trades out of the upper end of the fin. Not even soft foam cushions are allowed.

For the construction of the trailer for road transport the full freedom from any load must be carefully regarded.

V.5 PREVENTIVE MAINTENANCE

The whole surface of the glider is painted with a weather resisting, white polyester coat. Impurities may be washed off with a mild cleansing agent. Heavy impurities may be removed with a polish. For the paint maintenance only silicone-free agents must be used (e.g. 1 2-special cleansing agent-D2 from W.SAVER & CO., 5060 Bensberg, West Germany, - or the cleansing polish from LESONAL). Though the glider is rather insensitive, it should be protected as much as possible against moisture and humidity. If water has soaked into any components, these have to be stored in a dry room and must be turned over frequently;

The canopy is best cleaned with a special plexiglass cleansing agent; in an emergency lukewarm water will do. Rewipe only with pure, soft leather or with glove cloth. Never wipe on dry plexiglass.

The safety harnesses must be regularly checked for damage and tears. The metal parts of the harnesses must be checked for corrosion.

VI. CENTER OF GRAVITY (CG)

VI.1 WEIGHING PROCEDURE OF CG AT EMPTY WEIGHT

Prior to determining the CG in flight the CG at empty weight has to be established by weighing the glider. For this procedure the glider must be put on two pair of scales (one at the nose wheel and one at the tail skid).

NOTE: the glider must be set on the two pairs of scales very carefully in order to prevent that the scales get misaligned; (this could lead to erroneous results).

The Datum Line (DL) is situated at the wing leading edge of the straight center part of the wing.

Levelling means: wedge on rear top edge of fuselage 1000 : 52 horizontal.

Empty weight CG :

Weight at the nose wheel:	18a
Weight at the tailskid:	18a
Support point nose wheel:	in
Support point tailskid:	in

NOTE: determination of empty weight and empty weight CG must be done without any additional balance weights (e.g. trim cushion).

Be careful not to exceed the maximum weight of non lift producing parts when using maximum payload. The total weight of non lift producing parts contains the individual weights of fuselage, elevator and maximum payload and must not exceed 410 daN = 920 lbs (the payload must be reduced accordingly).

Weight and Balance Sheet

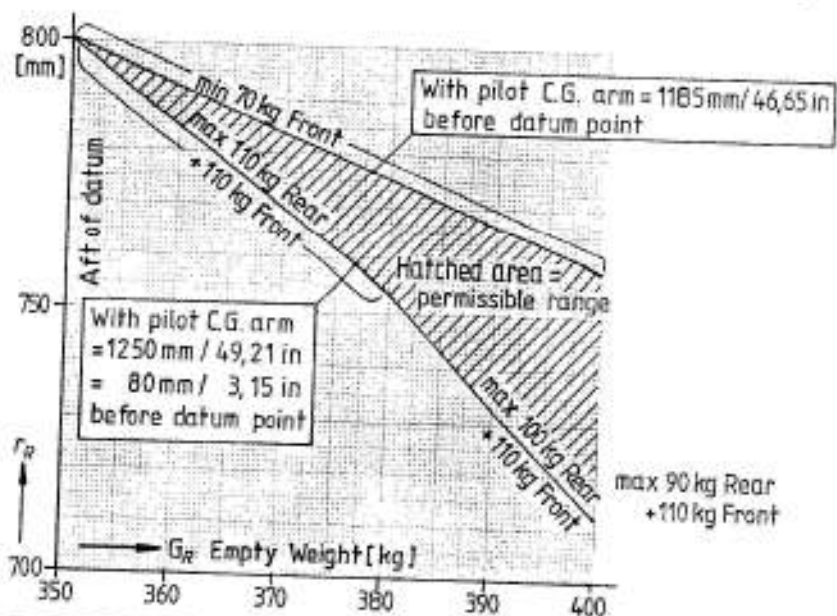
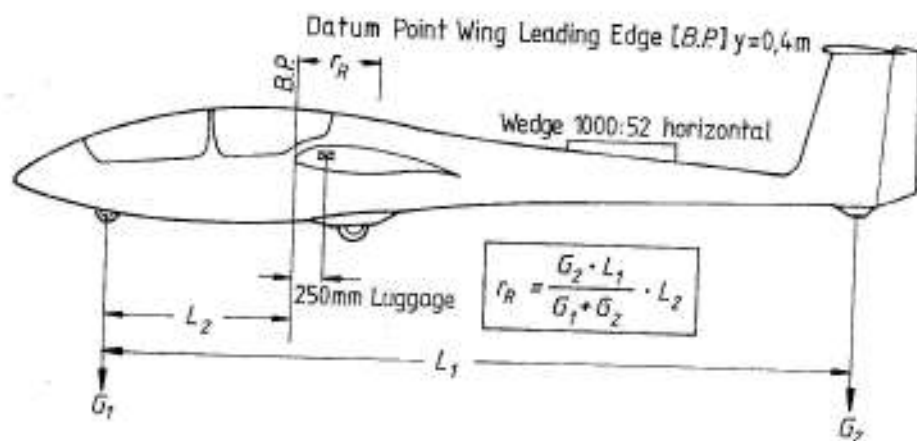

The CG should be recalculated after repair, repainting or installation of additional equipment, but not later than 4 years after the last weighing.

The empty weight, empty weight CG position and maximum load should be recorded after each weighing on page of the Flight Manual by a competent person.

VI.2 EMPTY WEIGHT CG POSITION

With the empty weight CG according to the below-mentioned limits and the pilot weights according to the load table the in flight CG will be within the approved range.

Empty Weight		CG Forward		CG aft	
daN	lbs	mm	in	mm	in
350	770	800	31,50	800	31,50
360	792	784	30,87	792	31,18
370	814	769	30,28	783	30,83
380	836	754	29,69	774	30,47
390	858	732	28,82	766	30,16
400	880	712	28,03	758	29,84

VI.3 WEIGHING RECORD

Det weighing, carried out by	Equipment list used for weigh- ing (date)	Empty weight kg (lbs)	Empt. CG behind da- sum mm (in)	Empty weight momentum	Max. payload kg(lbs)	Sig- nature

The empty weight momentum is necessary to calculate the in flight CG (load table).

March 9, 1983

CAUTION : Incorrect loading can deteriorate glider handling qualities and can cause hazardous flight conditions. The pilot in command is responsible for correct loading.

Never fly the glider from the rear seat only !!

VI.4 Calculation of CG at flight weight

	Weight [lbs]	x	arm [inch]	=	Momentum [lbs x inch]
Empty weight		x +		=	
Front pilot		x -	{ 46, 65 } * { 49, 21 }	=	
Rear pilot		x -		=	
Baggage		x +		=	
Sum of weight					Sum of momentum

$$\text{Position of flight CG} = \frac{\text{Sum of momentum}}{\text{Sum of weight}} = \boxed{} \text{ CG Flight [inches]}$$

* Note: Tall persons shall use the shorter value and set the backrest on the rear position.

Small persons shall use the longer value and set the backrest at the forward position.

VI.4 Calculation of CG at flight weight [metric system]

	Weight [kg]	x	arm [mm]	=	Momentum [kg x mm]
Empty weight		x +		=	
Front pilot		x -	{ 1185 } * { 1250 }	=	
Rear pilot		x -		=	
Baggage		x +		=	
<u>Sum of weight</u> →				<u>Sum of momentum</u> →	

Position of flight CG = $\frac{\text{Sum of momentum}}{\text{Sum of weight}} =$ CG Flight [mm]

* Note: Tail persons shall use the shorter value and set the backrest on the rear position.

Small persons shall use the longer value and set the backrest at the forward position.

VI.4 Calculation of CG at flight weight

EXAMPLE !

	Weight [lbs]	x	arm [inch]	=	Momentum [lbs x inch]
Empty weight	814	x +	30,55	=	+ 24 8 69
Front pilot	187	x -	$\left. \begin{matrix} 46,65 \\ 49,21 \end{matrix} \right\}^* 47,24$	=	- 88 33,88
Rear pilot	165	x -	3,15	=	- 519,75
Baggage	22	x +	9,84	=	+ 216,48
<u>Sum of weight</u>	<u>1188</u>		<u>Sum of momentum</u>	=	<u>15730,85</u>

$$\text{Position of flight CG} = \frac{\text{Sum of momentum}}{\text{Sum of weight}} = \boxed{13,24} \quad \text{CG Flight [inches]}$$

- * Note: Tall persons shall use the shorter value and set the backrest on the rear position.
 Small persons shall use the longer value and set the backrest at the forward position.

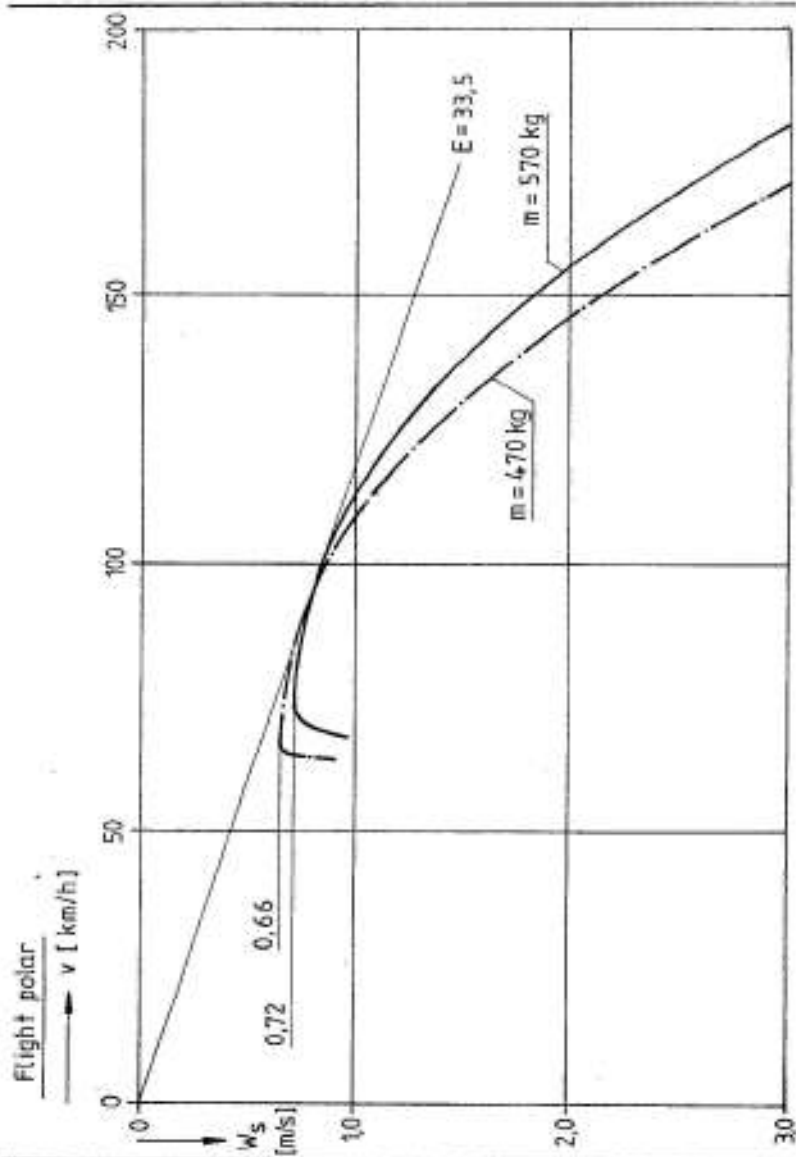

LUBRICATION SCHEME

- (M) Clean and lubricate to every rigging.
- (A) Disassemble and lubricate on annual inspection.

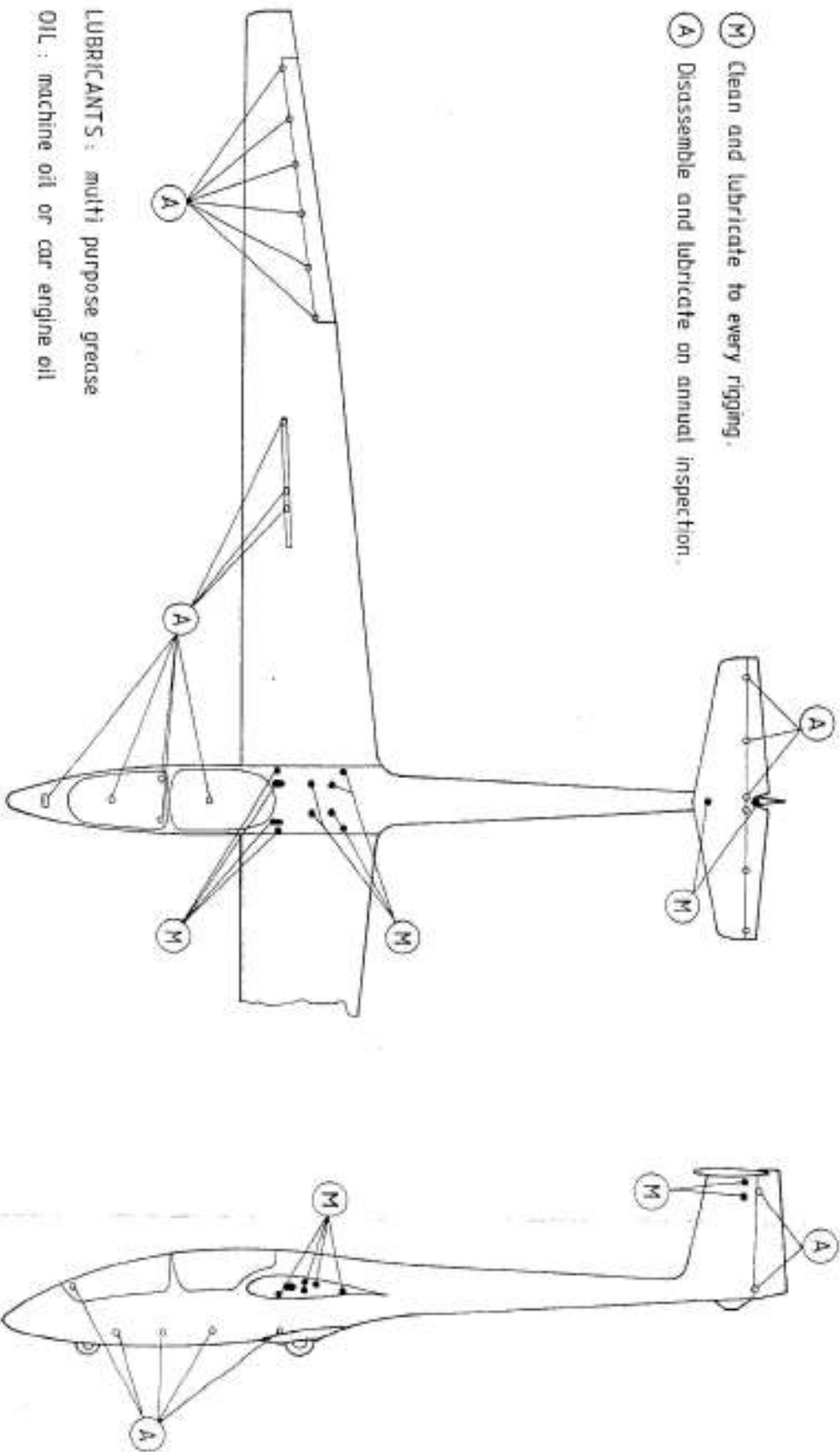

LUBRICANTS: multi purpose grease
OIL: machine oil or car engine oil

Three view - Rigging data

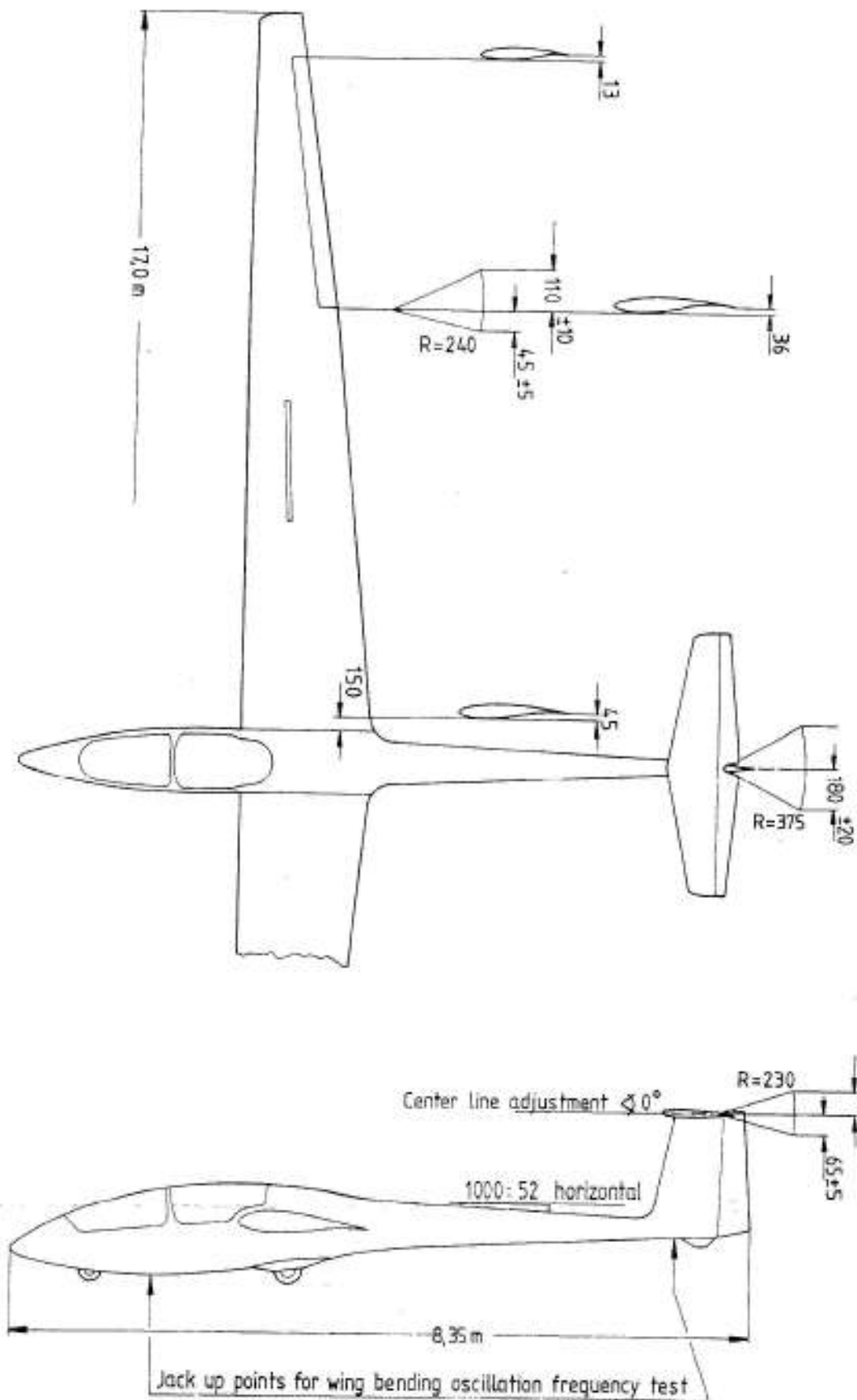

ASK-21 LOAD LIMITS (NO BALLAST - NO BAGGAGE)

