



ASK 21

The ASK 21 is a two-seater midwing with 17m span. This aircraft stands out particularly by its wide range of flying tasks. The ASK 21 accompanies the student pilot from instruction up to the first cross-country or competition flights. The experienced pilot may use its suitability for aerobatics and cloud flying. Its easy handling on the ground as well as in flight must also be pointed out. The high production quality, as well as the low-maintenance and very rugged design offer a versatile aircraft for everybody, fit for every-day service and lasting in value. It is an acquisition which pays off for syndicates and clubs.

The fuselage shell offers to the pilot a high level of passive accident safety. The plexiglass canopies are hinged fore and aft and together with the upwards hinging instrument panel in the front seat they offer a comfortable entry and exit. The layout of the canopy locking levers and the fitting of a canopy interlock mechanism guarantee reliably the locking of the canopies, particularly of the rear canopy which is valuable on solo flights or when carrying passengers.

The comfortable rubber-shock-mounted landing gear not only absorbs the smaller bumps which are common on every take off and landing, but is also very forgiving of heavy landings. Especially flight instructors appreciate after a long instruction day the convenience of the comfortable non-fatiguing seat position and of the easy-to-use and easily accessible operating levers.

A true instruction sailplane

The ASK 21 is a design by Rudolf Kaiser, one of the most famous sailplane designers of our times.

Already with the predecessor sailplane type ASK 13 he succeeded to design an aircraft which came up to all requirements of instruction and performance flying. And with the ASK 21 Kaiser was successful in conveying the good characteristics of the ASK 13 also to the fiber composite construction. Meanwhile more than 650 units have been built and so the ASK 21 may be regarded as the standard type of instruction sailplane.

Now as before „up to date“

It is not only its elegant appearance on the ground and in flight which makes clear that Rudolf Kaiser has designed the ASK 21 very far-sighted at the time. Even after being in production since some years already, the ASK 21 still comes up to all requirements. With this two-seater the student and the solo pilot gets an aircraft which stands out for easy handling and extremely harmless flight characteristics. Particularly the excellent low speed flight characteristics together with its low all-up weight work out very positively in weak thermals. Moreover, the low all-up weight pays off also for winch launches where considerably more height in tow is gained compared to bigger and heavier two-seaters. This is a pre-condition for an effective instruction operation in flying circuits or for reaching thermals.

The good glide ratio enables pilots to gain with the ASK 21 their first experience in cross country or competition flights. Another quite new thing was that the ASK 21 got type certification for full aerobatics and for cloud flying. It is certified for the following aerobatics: Loop, Turn, Split 'S', Immelmann, Slow Roll, Steep Climbing Turn, Chandelle, Lazy Eight and Inverted Flight.

Its easy ground handling due to the low tail weight and low all-up weight must also be pointed out.

Handicapped pilots flying a sailplane ?

In order to enable also pilots with disabled legs to do gliding, some ASK 21 have already been modified accordingly. Schleicher offers to this purpose a modification kit where the rudder is

actuated by means of an additional hand lever at the left cockpit wall. The airbrake lever engages in a similar way as a flap lever so that one hand is free to actuate the rudder. The additional actuating levers are easily and quickly removable so that the ASK 21 can also be operated in the usual way.

Experience with the operation of such modified ASK 21 has shown that the actuating levers are ergonomically very well laid out and stand out for low actuating forces.

Design Service

It is often the small details which improve the every-day suitability of an aircraft. as e.g. the front instrument panel being designed to hinge upwards with the canopy which offers a comfortable entry and exit.

The layout of the canopy locking levers and the fitting of a special canopy interlock mechanism guarantee reliably the locking of the canopies, particularly of the rear canopy which is valuable on solo flights or when carrying passengers.

High Production Quality and Safety

The high production quality which is known from Schleicher products, as well as the well-devised and low-maintenance design offer an aircraft which is fit for every-day service, versatile, and lasting in value, for everybody. Thanks to its easy and unproblematic handling this aircraft can and may surely be flown by everybody. It is an acquisition which pays off for syndicates and clubs.

Also just its use in the harsh instruction conditions has demonstrated that the ASK 21 is a very rugged aircraft without any teething troubles.

Particular attention was paid to the crashworthiness of the ASK 21. Not only the automatic elevator connection but also the construction of the fuselage contribute considerably to the safe operation of the aircraft. For example, the fuselage shell is a rugged GRP tubuscore honeycomb sandwich which affords the pilot a high level of passive accident safety with low weight of structural components.

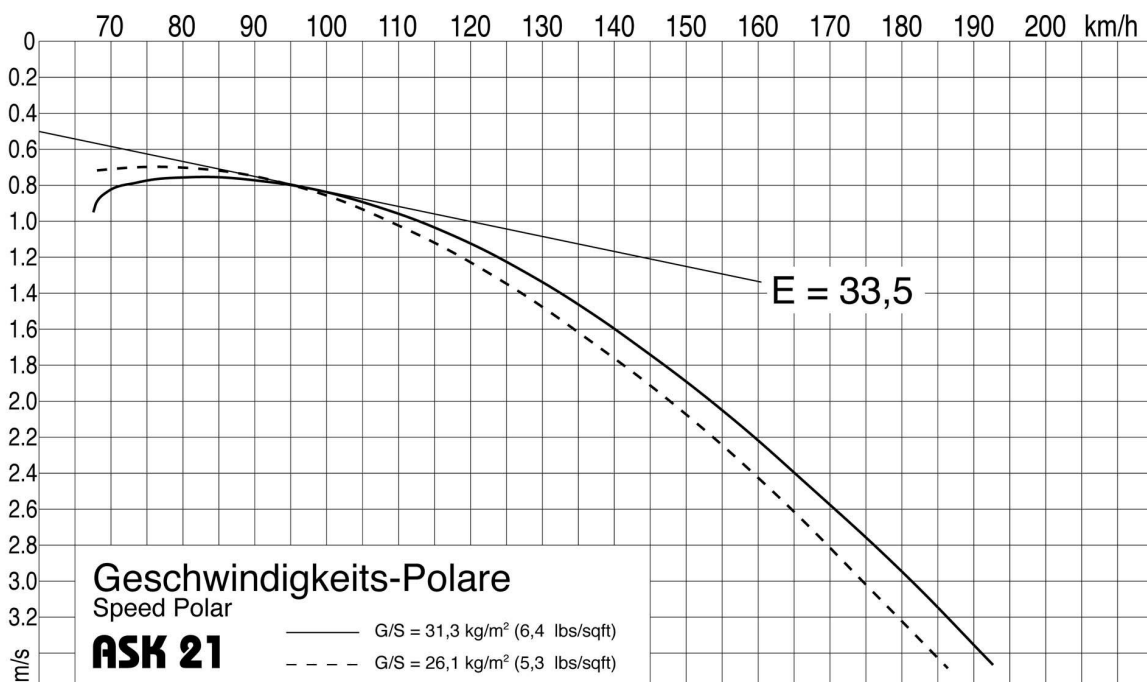

Standard Equipment:

The basic version of the sailplane ASK 21 already gives you a liberally equipped aircraft:

The double-wall fuselage shell uses an 8 mm thick tubus core between both supporting GRP laminate skins. This sandwich construction provides a safety cockpit which gives the pilot a maximum possible protection in case of emergency.

The automatic elevator connection prevents effectively the possibility of taking off without connected elevator. The canopy closing system with the interlock mechanism adds further to the safety.

The plexiglass canopies are hinged fore and aft; having the advantage of an efficient tongue and groove type sealing.

The two largely dimensioned rubber-shock absorbers of the landing gear and the large 5.00-5 main wheel are very forgiving

of heavy landings. Also the smaller bumps which are common on every take off and landing are well absorbed thus saving the backbone of the flight instructor.

Rudder pedals and seat back rests are comfortably adjustable in both seats. There is ample space also for tall pilots.

All operating levers are easy-to-use and easily accessible. Adjustable and pivot-mounted fresh air nozzles at the cockpit wall provide sufficient cockpit ventilation.

It goes without saying that the installation of tow release couplings for winch launch as well as for aero tow is standard.

The push rods of aileron, elevator, and airbrakes are running smoothly in anti-noise ball-bearings. The actuating levers and bellcranks use also ball bearings which guarantee smooth running and long service life. The rudder is actuated by steel cables.

DESIGN SPECIFICATION

Two-seater sailplane, fiber composite construction, midwing configuration with T-tail, for instruction, aerobatics and performance flying.

FUSELAGE

GRP tubuscore honeycomb sandwich fuselage with roomy safety cockpit. In flight adjustable rudder pedals, front & rear. TOST C.G. tow release coupling and TOST aero nose tow release coupling. Rubber-shock-mounted landing gear with large 5.00-5 tire. Hydraulic disc brake which is connected to the airbrake lever. Fixed nose wheel 4.00-4. Rubber-shock-mounted tail skid or (as optional extra) tail wheel 210 x 65. Cockpit ventilation through adjustable fresh air nozzles at the right cockpit wall.

CANOPIES AND INSTRUMENT PANELS

The full-vision plexiglass canopies are hinged fore and aft. Canopy interlock mechanism to guarantee safe locking of the rear canopy. The front instrument panel is made to hinge upwards with the canopy; even when the canopy is open, the instruments are still covered.

WING

The two-part double-tapered wing is built as a fiberglass sandwich with PVC hard foam core and GRP roving wing spars. Large dive brakes on the wing upper surface. Straight-forward wing assembly by conventional tongue and fork spar extension with two cylindrical main pins.

CONTROL CIRCUITS AND FITTINGS

Aileron, elevator, and airbrakes are actuated by push rods running in anti-noise ball-bearings. The actuating levers and bellcranks use also ball bearings. The rudder is actuated by steel cables. Levers and fittings are welded steel or milled Duraluminium respectively.

TAILPLANE

T-tail (elevator with stabilizer) in GRP-hard foam sandwich-construction. Control surfaces partly mass balanced. Low actuating hand forces. Elevator trim via a trim lever next to the stick. Automatic elevator connection. VHF-antenna in the fin.

BOARD EQUIPMENT AND ACCESSORIES

Pitot in the fuselage nose. Static pressure vents (for the A.S.I.) in the fuselage tail boom left and right. Connector for Total Energy tube on the fuselage top. VHF-antenna in the fin. Seat cushions front & rear. 5-part safety harnesses.

OPTIONAL EXTRAS

Fixed tail wheel (210 x 65), aerodynamically well faired. Trim weights mounting support for 10 x 1kg lead plates. Mounting support for 2 oxygen bottles à 4 liters. Tail dolly. Mounting support for barograph.

TECHNICAL DATA

Span	17 m	55.77 ft	Wing loading (85 kg payload)	24.5 kg/m ²	5.01 lbs/sqf
Wing Area	17.95 m ²	193.21 sqft	Wing loading (200 kg payload)	31.0 kg/m ²	6.34 lbs/sqf
Wing aspect ratio	16.1	16.1			
Fuselage length	8.35 m	27.39 ft	Payload cockpit front	max. 110 kg	242.5 lbs
Cockpit height	0.90 m	2.95 ft	Payload cockpit rear	max. 110 kg	242.5 lbs
Cockpit width (clear width)	0.68 m	2.23 ft	Max. speed	280 km/h	151 kts
Height at tailplane	1.55 m	5.08 ft	Min. speed (single-seated)	62 km/h	33.4 kts
			Min. speed (two-seated)	65 km/h	35 kts
Wing airfoil	Wortmann FX S 02-196 and FX 60-126		Maneuvering speed	180 km/h	97 kts
Maximum load factor (180 km/h)	+6.5 -4.0		Dive brakes extended	up to 250 km/h	up to 135 kts
Maximum load factor (311 km/h)	+5.3 -3.0		Minimum sink (single-seated)	0.65 m/s	128 ft/min
Empty mass with min. equipment	appr. 360 kg	~ 794 lbs	Glide ratio (single-seated, at 85 km/h)	34	34
Max. take-off mass	600 kg	1323 lbs	Glide ratio (two-seated, at 90 km/h)	34	34

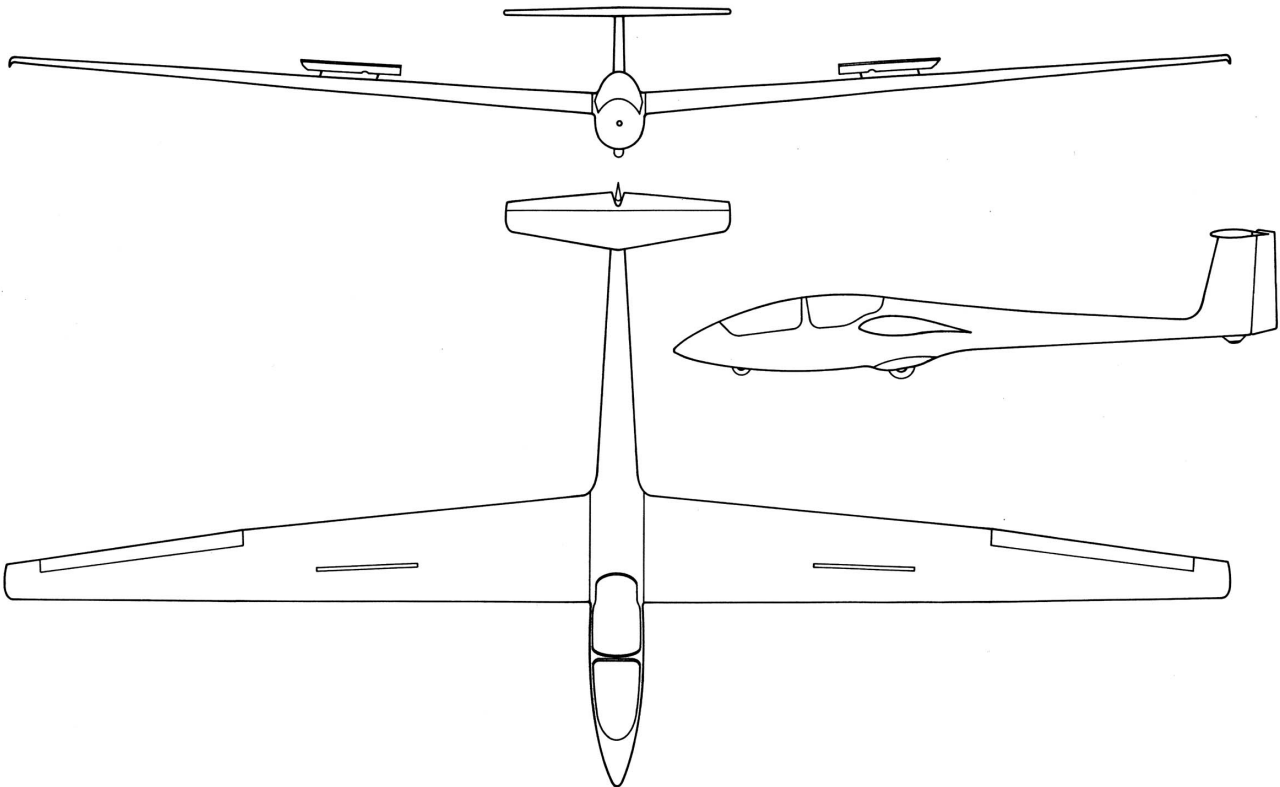

Alexander Schleicher GmbH & Co. Segelflugzeugbau

P.O.Box 60 D-36161 Poppenhausen (Wasserkuppe)
Huhnrain 1 D-36163 Poppenhausen (Wasserkuppe)

Tel. ++49 (0) 66 58 / 89-0
Fax ++49 (0) 66 58 / 89 40
e-mail: info@alexander-schleicher.de
homepage: www.alexander-schleicher.de